



MODELO SINALOBI

Instrucciones de montaje

Installation instructions

As instruções de instalação

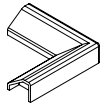
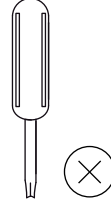
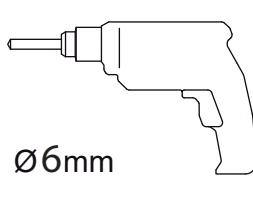
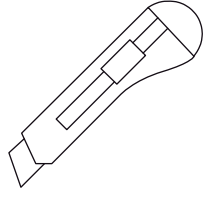
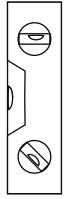

x1
[27]EA0985

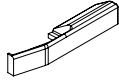

x1
IZQ:[28]HI0986
DCH:[29]HD0986

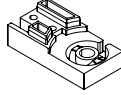

x1
IZQ:[30]BI980I
DCH:[31]BI980D

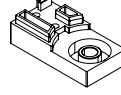

x1
IZQ:[32]BS980I
DCH:[33]BS980D

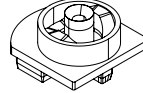

x2
[34]TH9810

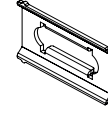

x2
[35]PT0989

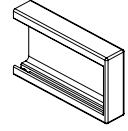

x2
[36]TT9830

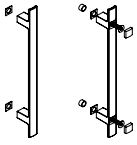

x2
[22]AD0255



x2
[23]RT0087



x2
IZQ:[24]BV907I
DCH:[25]BV907D

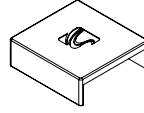

x1
[26]TE9820



x2
IZQ:[37]SOP. PARED GUÍA
DER:[38]SOP. PARED GUÍA

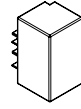

x1
[39]CONJUNTO CODO



x1
[18]VT0006



x1
[19]VT0006



x1
[20]VT0006

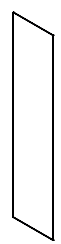

x1
[21]VT0006



x2
[40]JUEGO TAPÓN

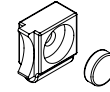

x2
[41]JUEGO TOPE RUEDA

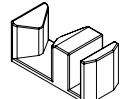

x1
[42]GUÍA INFERIOR

KIT ACC. ZAMAK SINALOA
KS9624



x3
[43]A01256

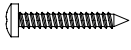

x3
[44]T04832



x2
[45]T04813



x4
[46]T03545



x3
[47]T00638



x4
[48]T00440



x4
[49]T03916



x4
[50]T04219

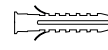

x3
[51]TN0630



x3
[52]TN0830

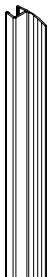

x1
[17]J10920



x2
[16]V14230



x1
[15]P12470



x1
[14]P12480

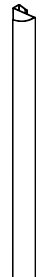

x1
[13]V11000

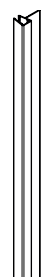

x1
[12]J10160



x2
[11]J09300

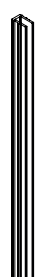

x2
[10]T51020



x1
[9]J03350

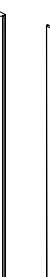

x2
[8]B51780



x2
[7]J51010



x2
[6]G51000



x2
[5]U51030



x1
[4]M51740



x1
[3]H51760



x1
[2]B51750



x1
[1]C51730

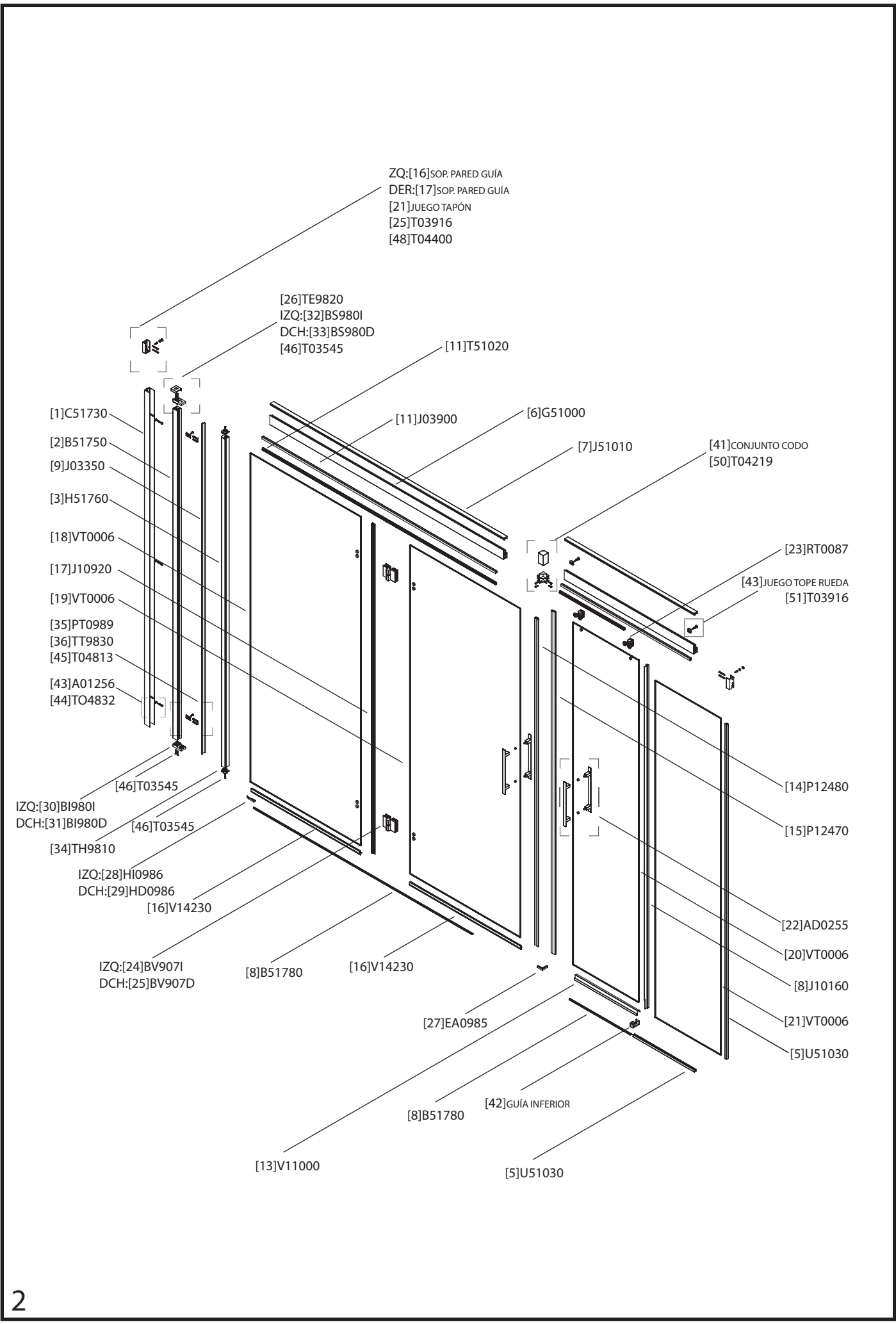

1

1a

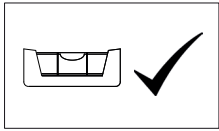
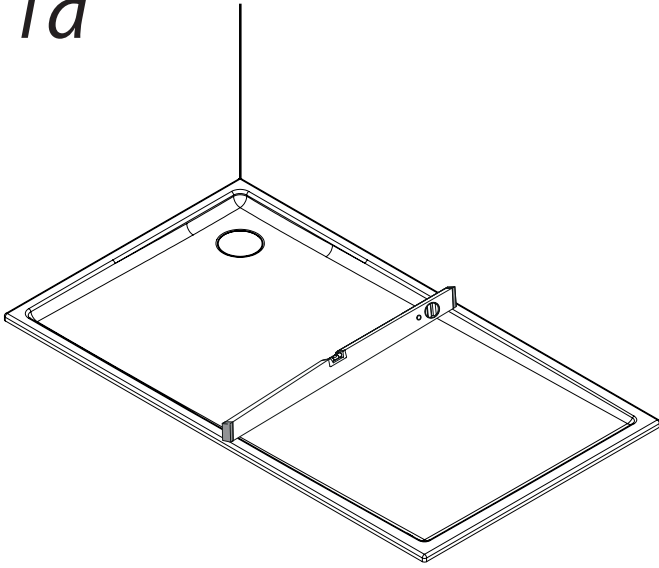

1b

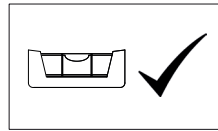
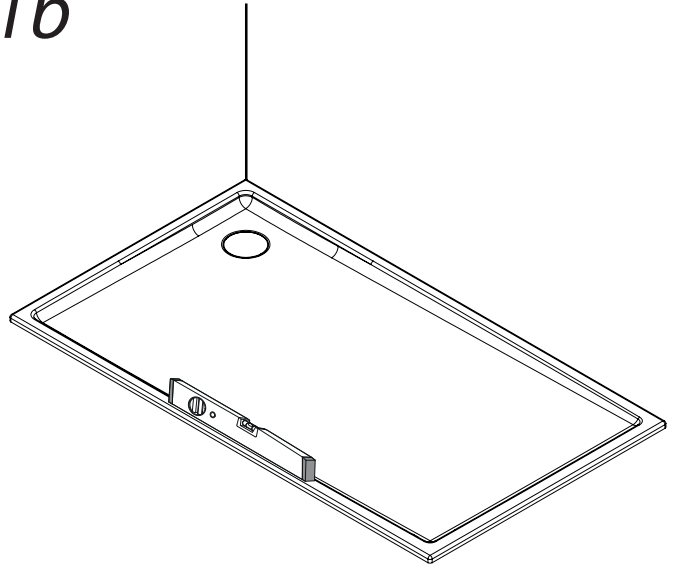

2

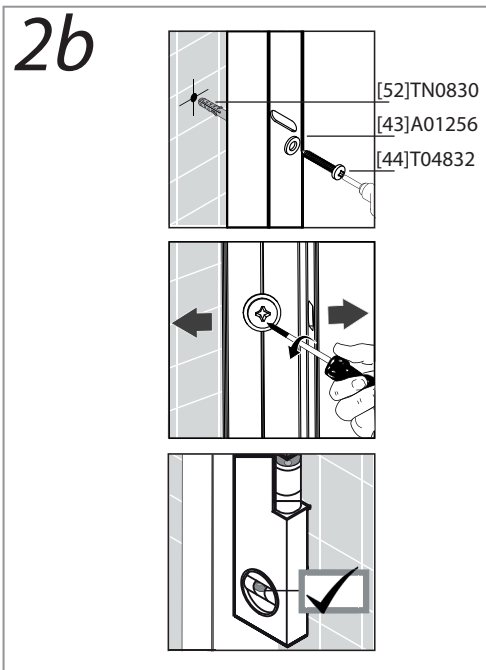
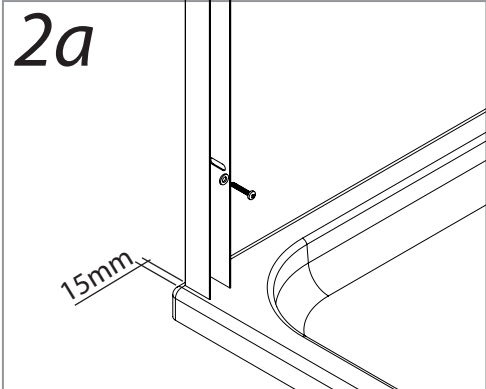
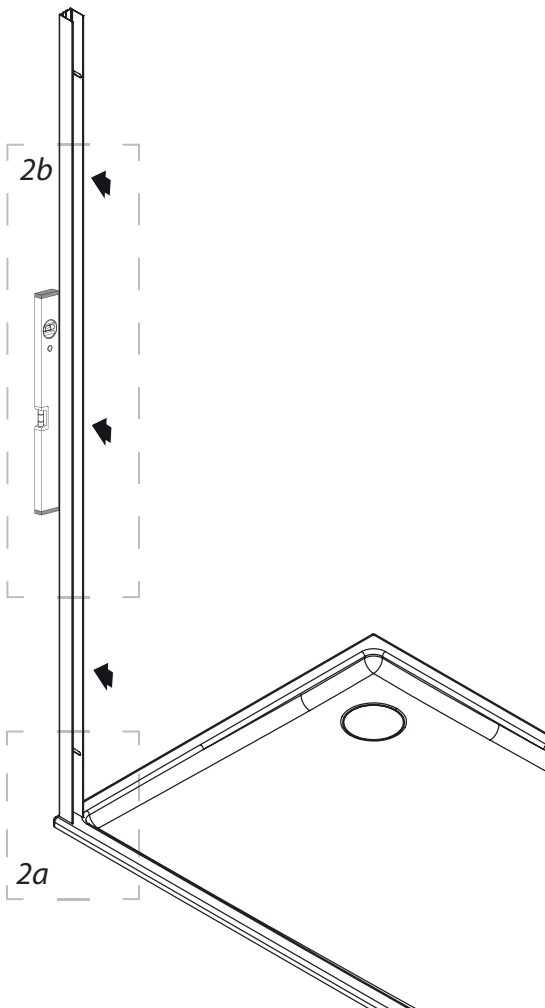

3

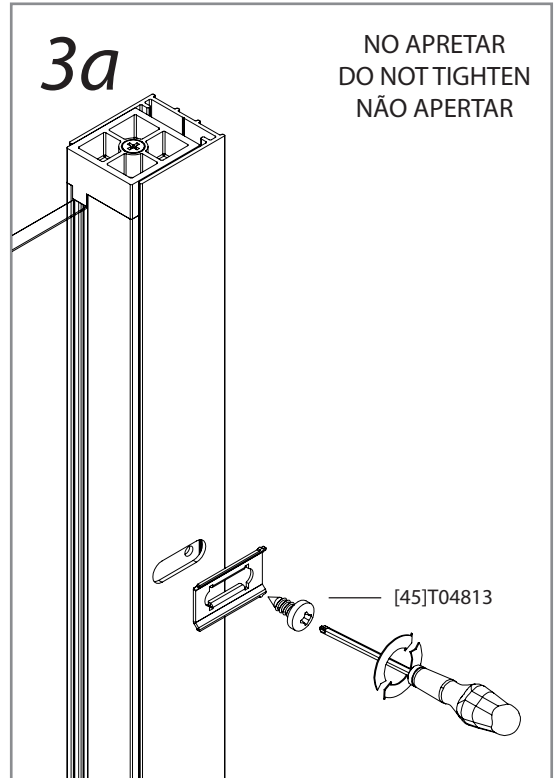
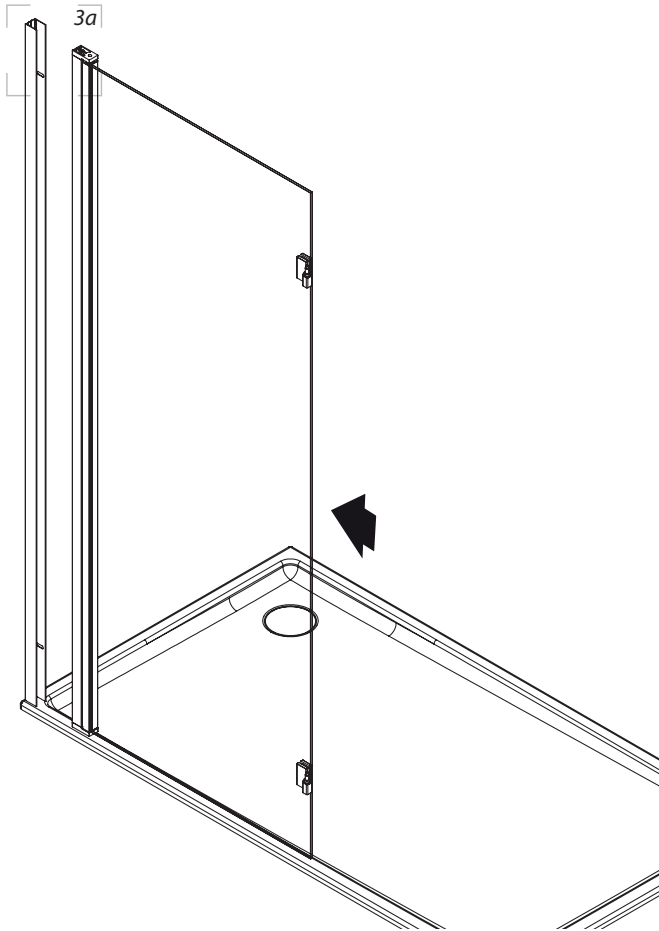

4

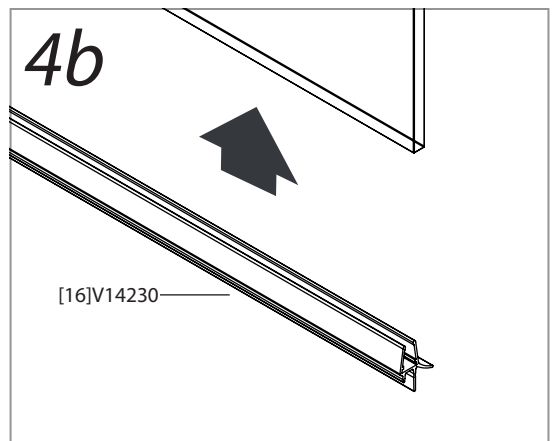
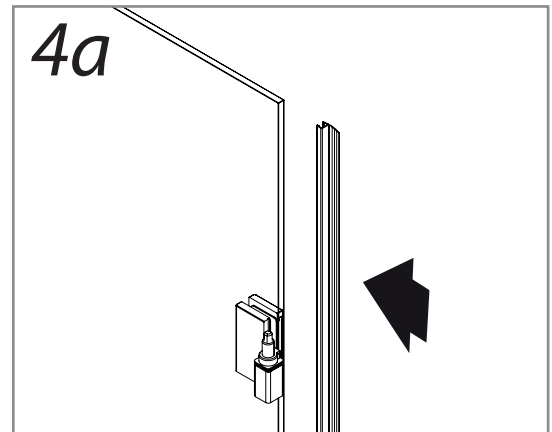
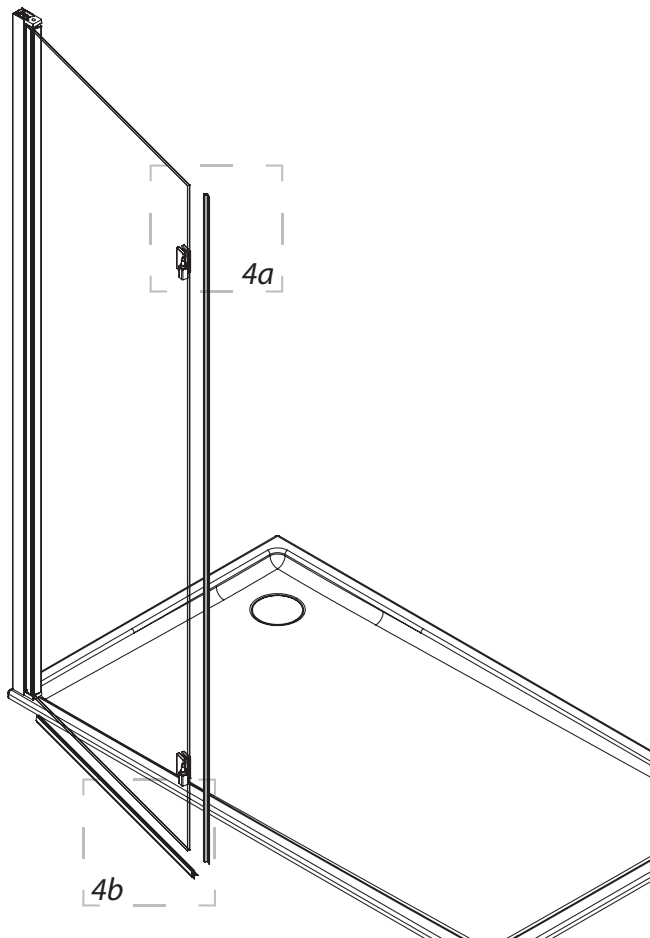

5

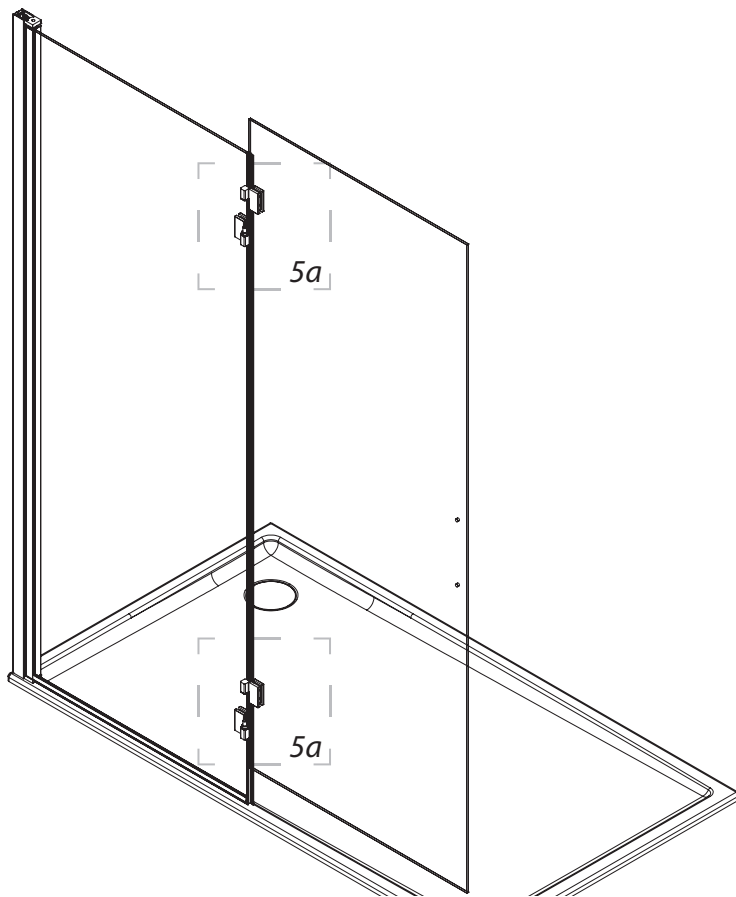

5a

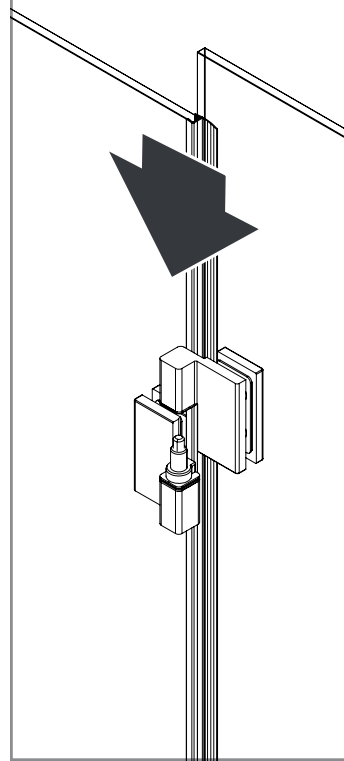

6

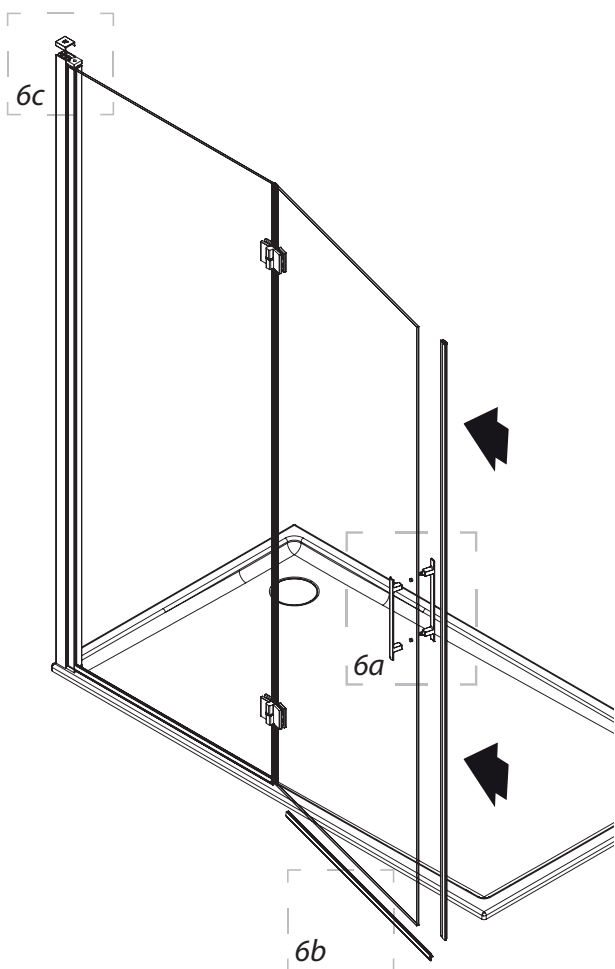

6a

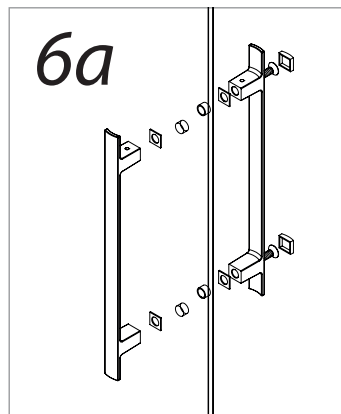

6b

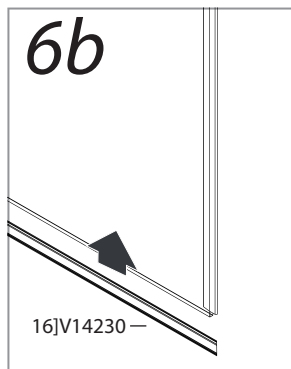

6c

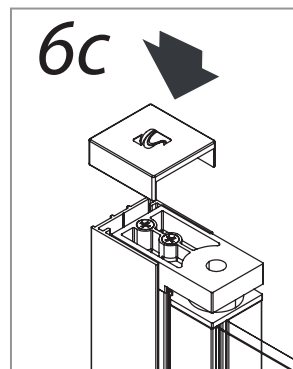

7

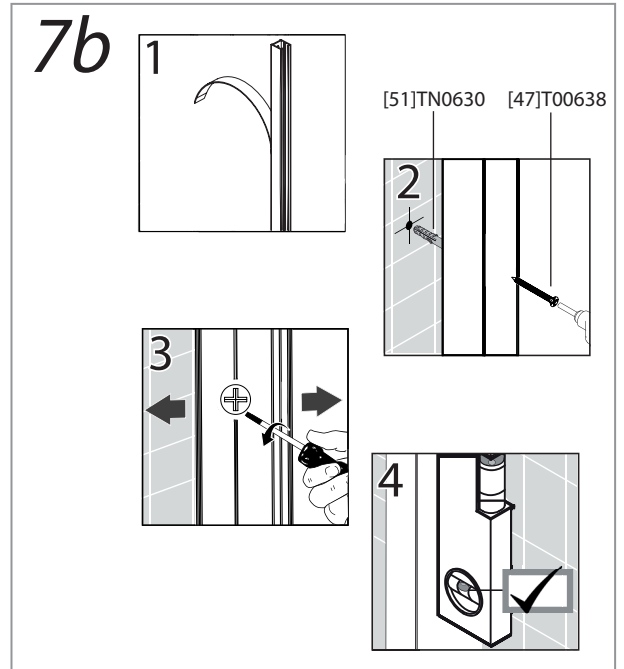
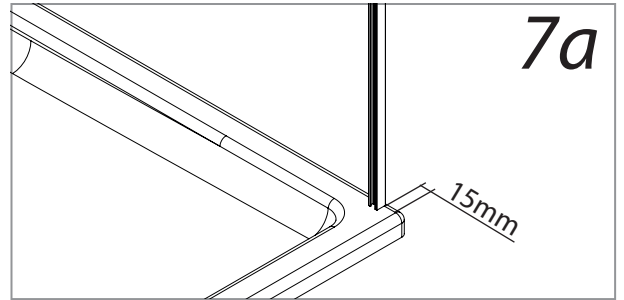
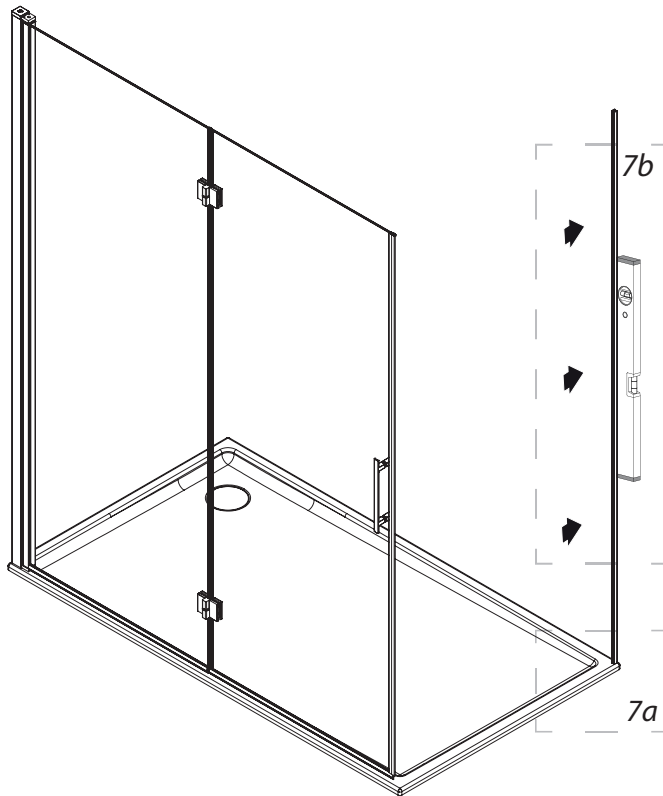

8

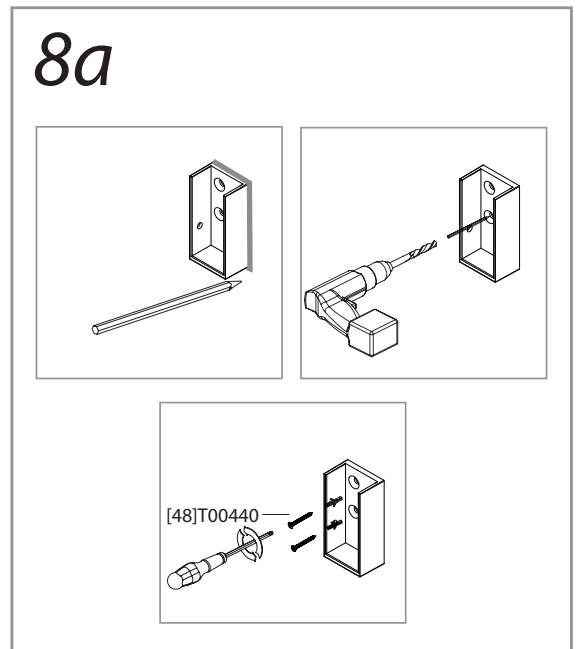
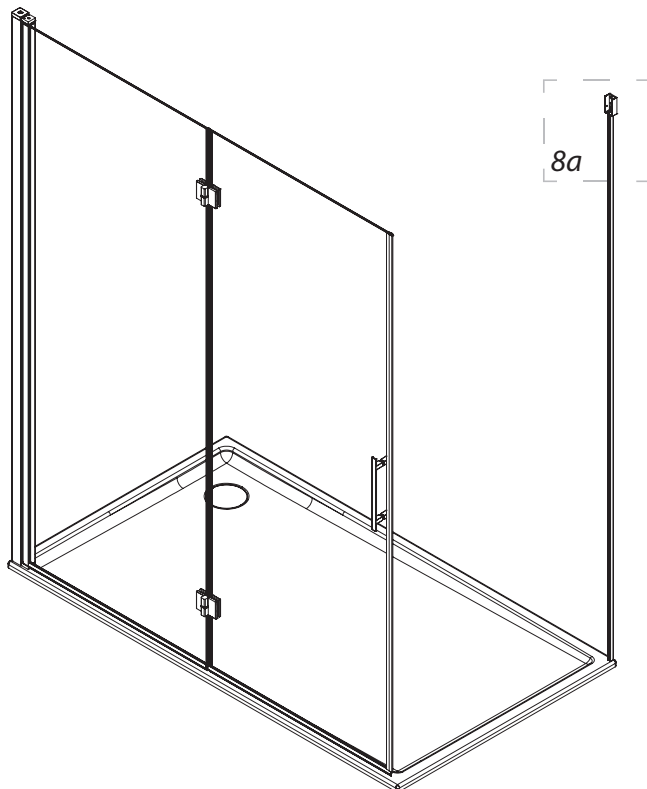

9

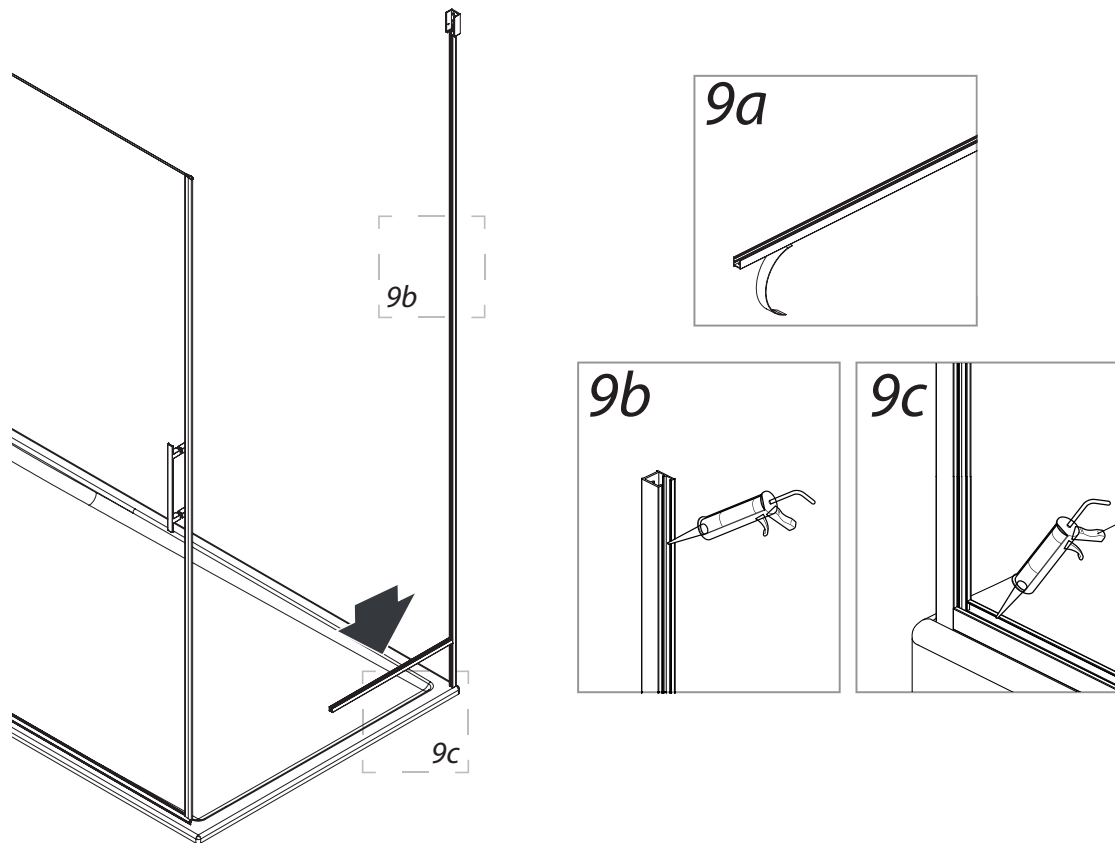

10

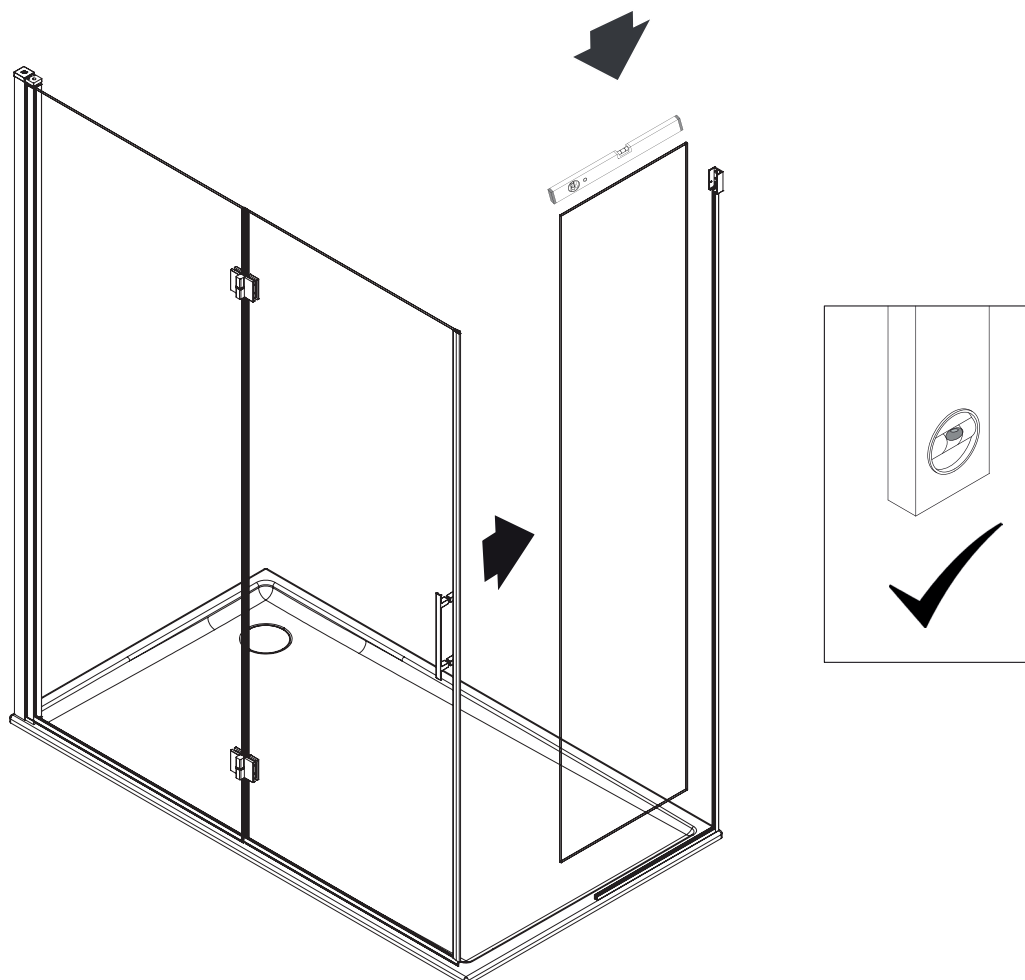

11

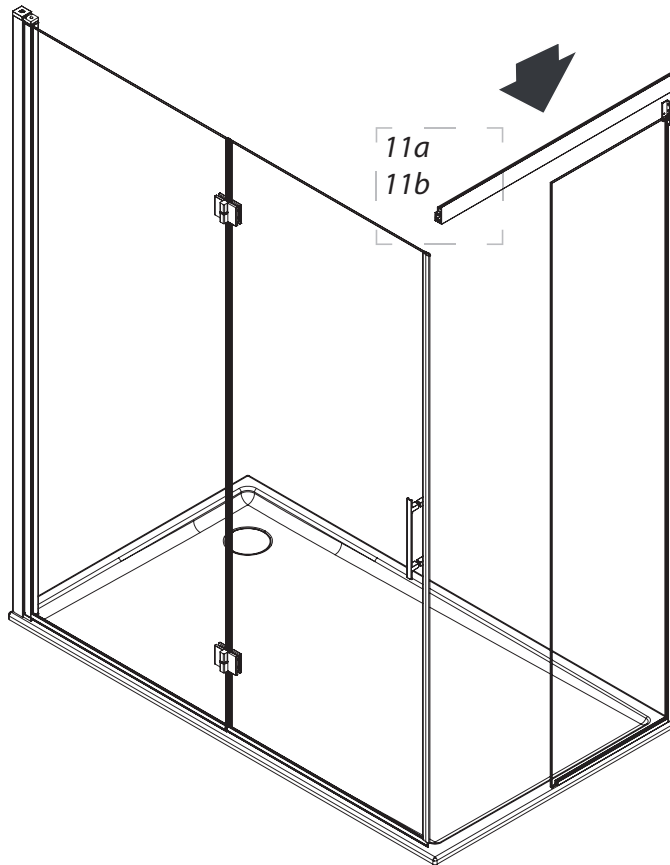

11a

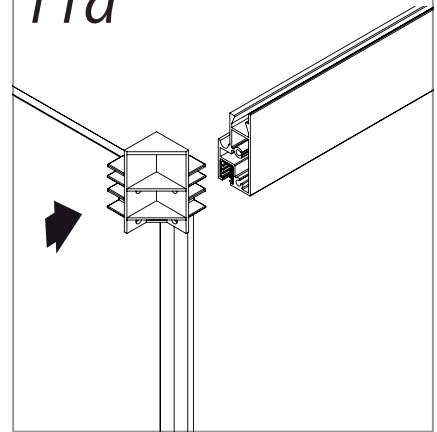

11b

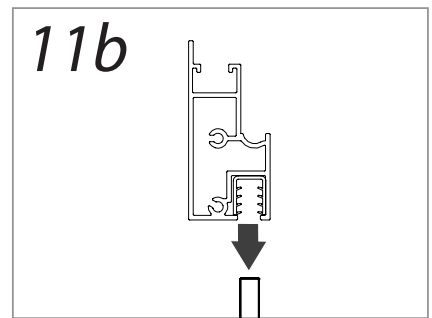

12

12a

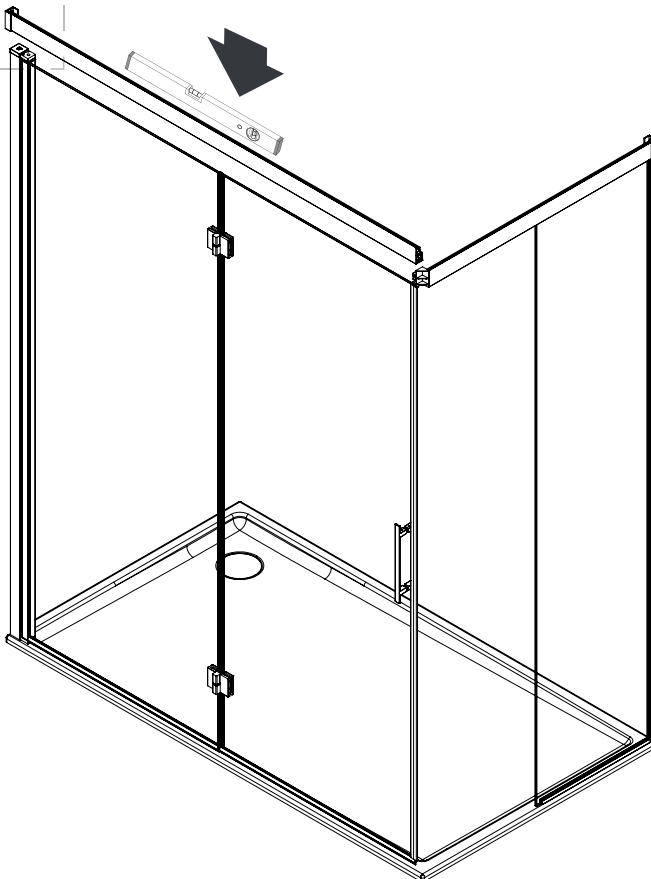

12a

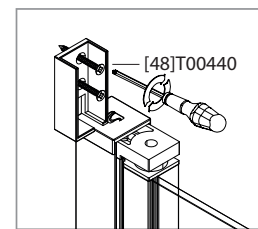
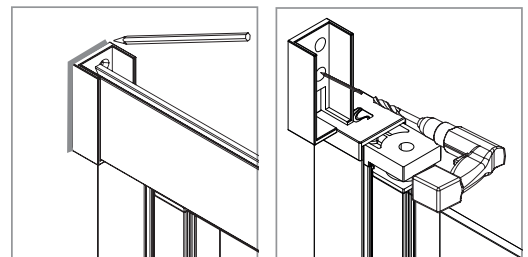

13

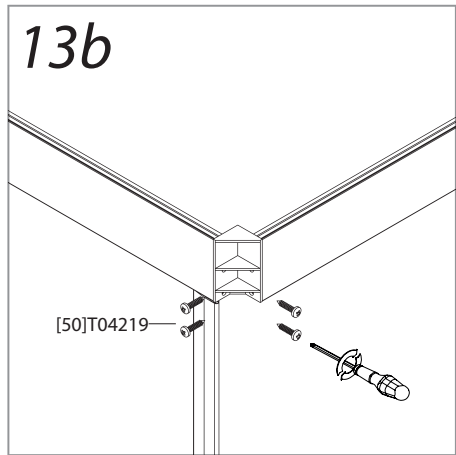
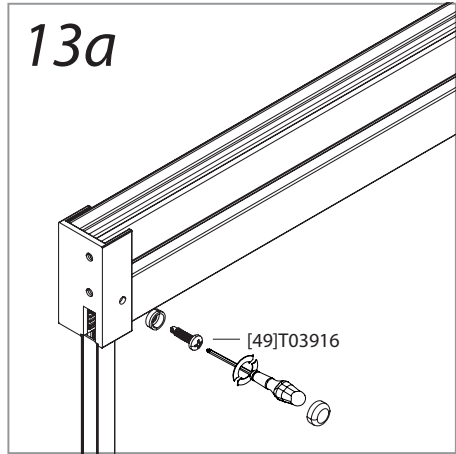
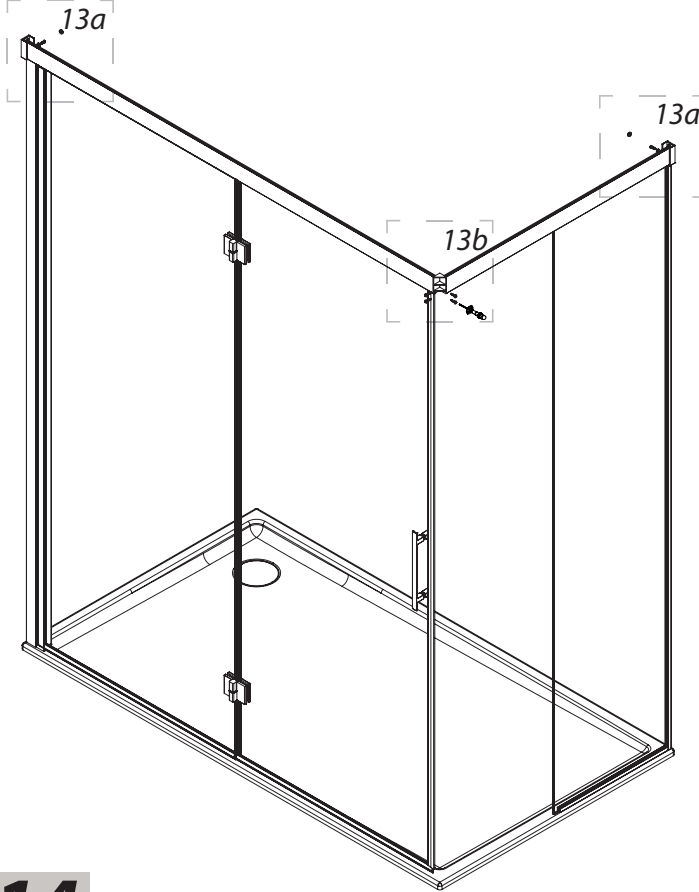

14

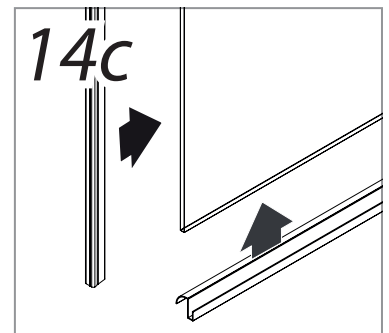
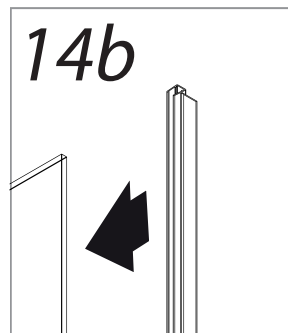
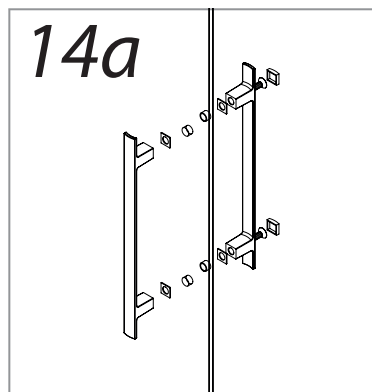
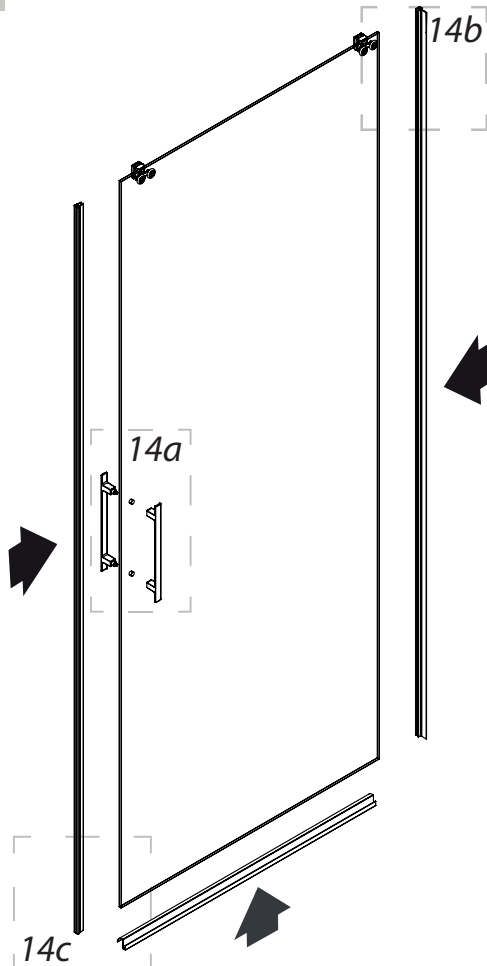

15

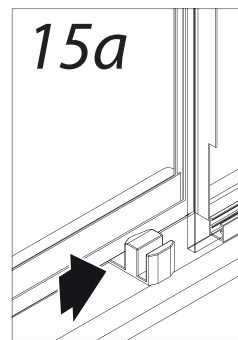
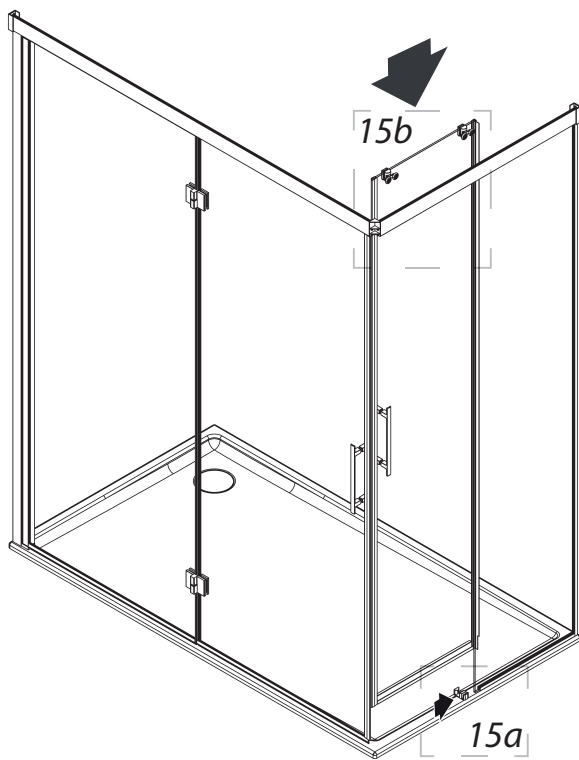

16

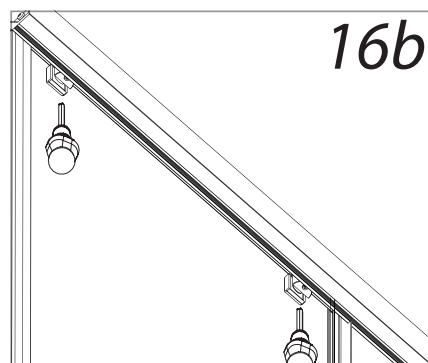
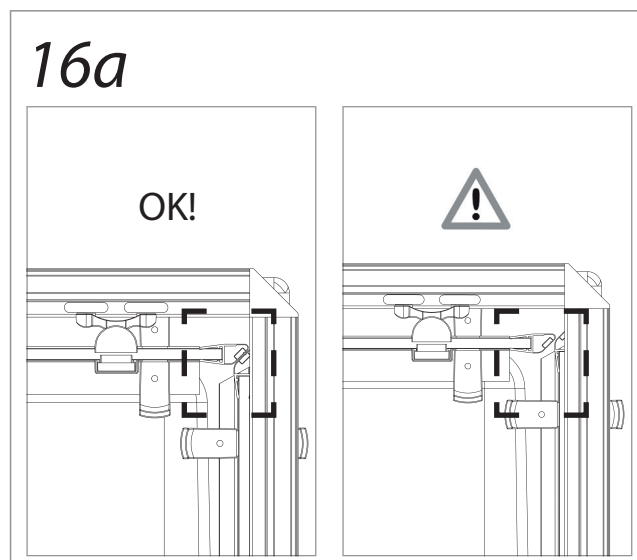
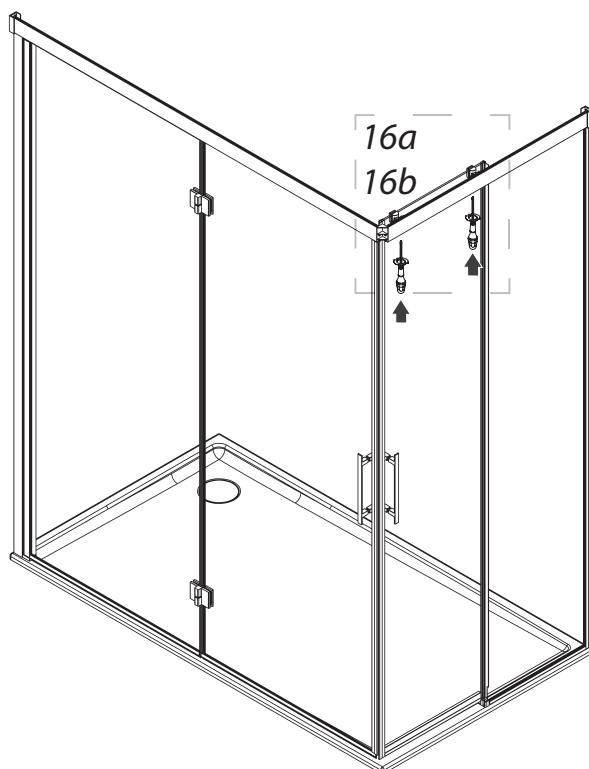

17

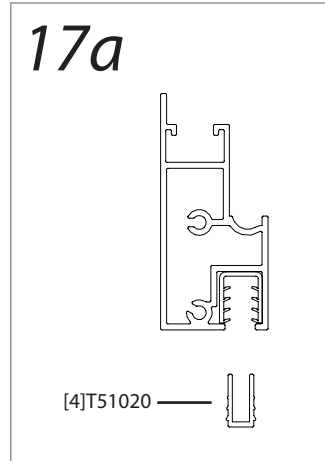
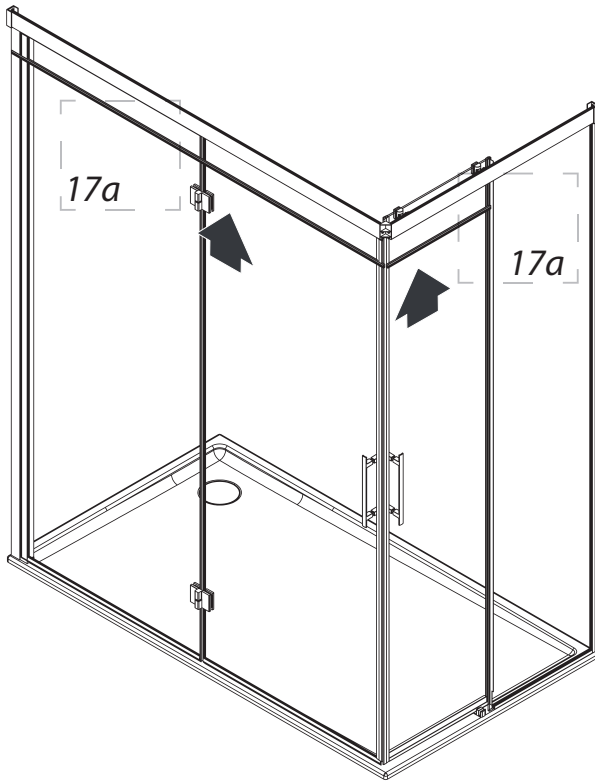

18

18a

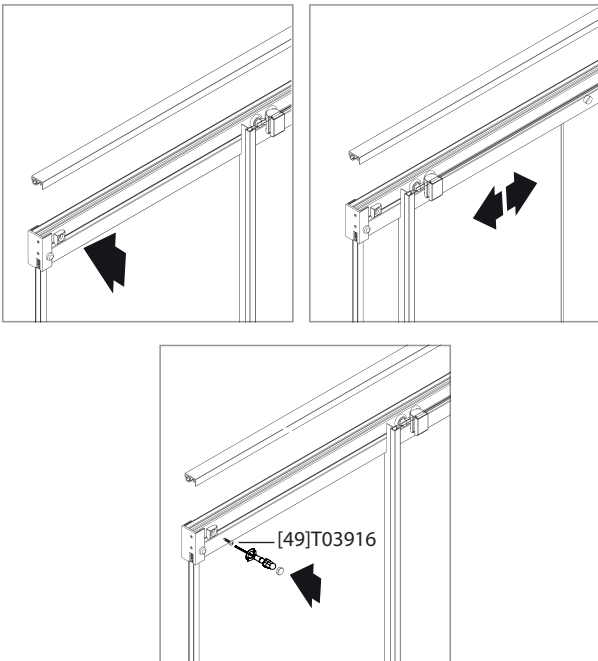

18b

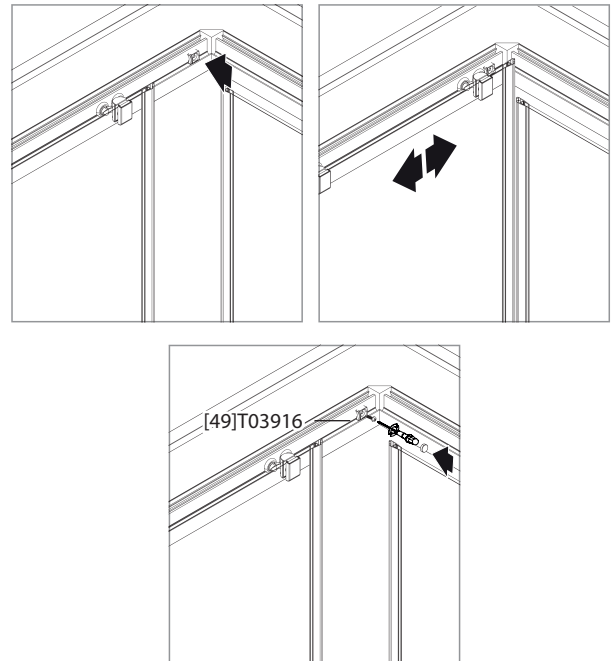

19

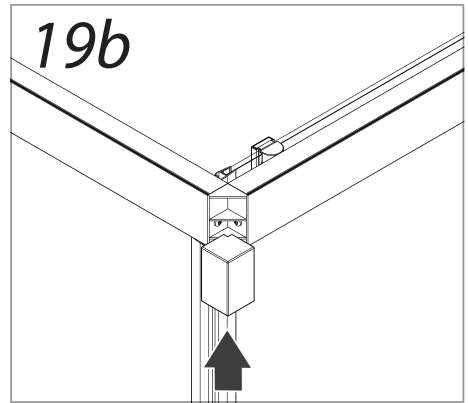
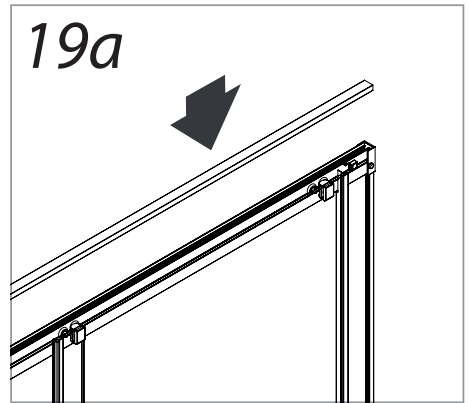
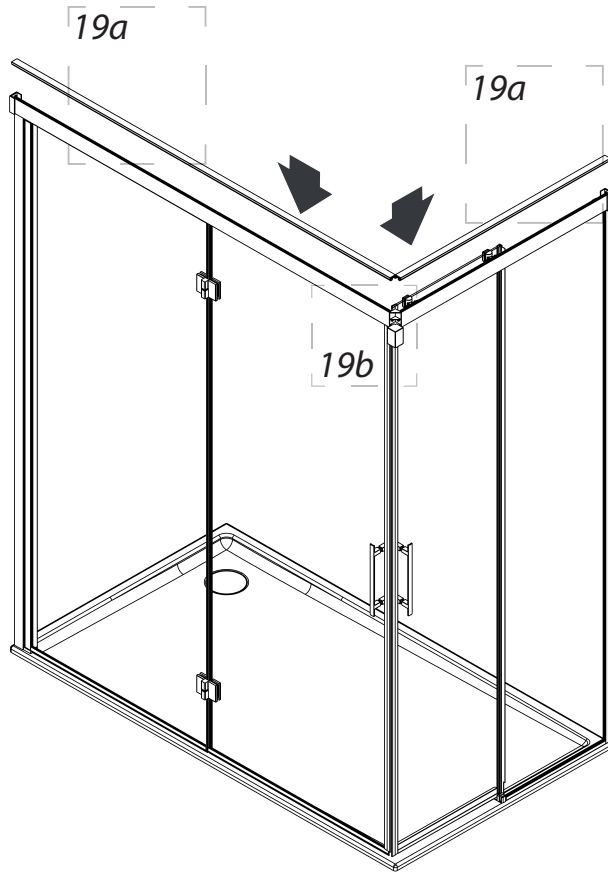

20

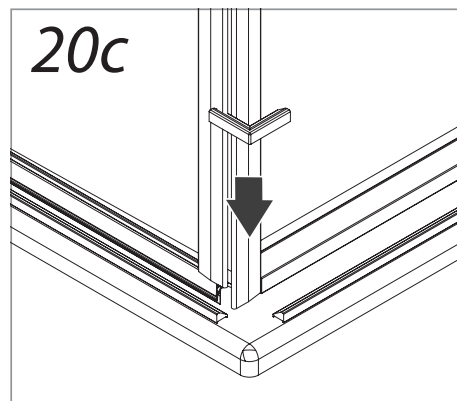
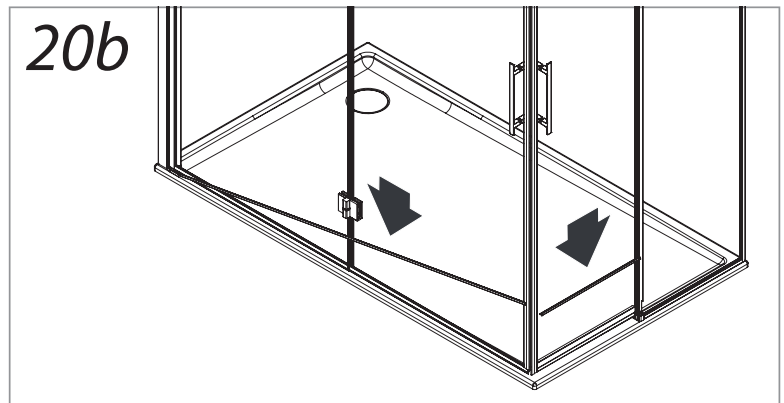
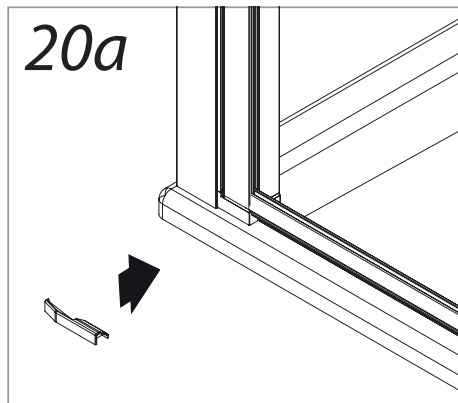

21

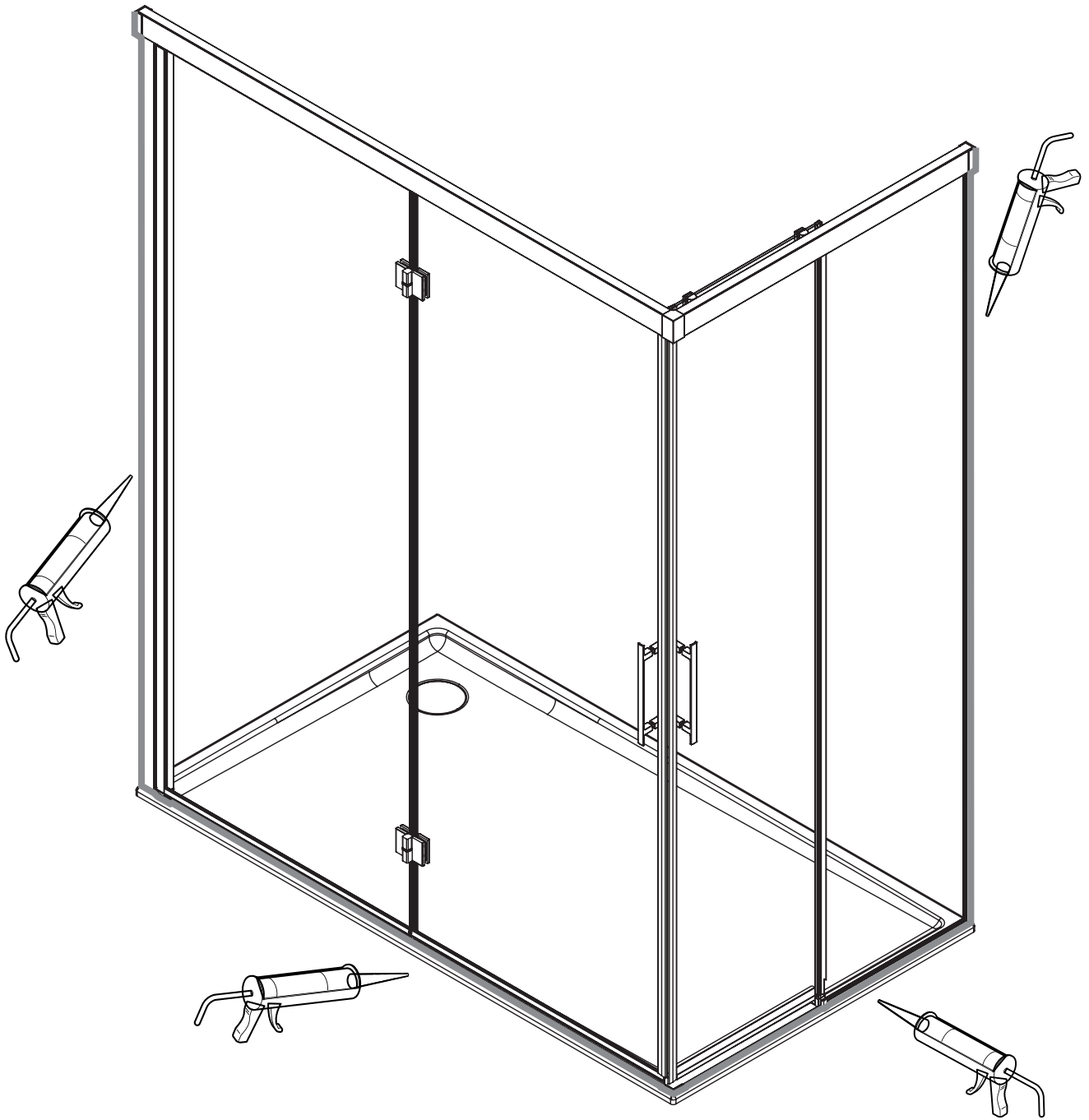

LIMPIEZA CLEANING LIMPEZA

Para el cuidado de los productos Hidroglass y mantenerlos en perfecto estado, se aconseja secar con un paño o bayeta los accesorios (Bisagras y componentes), que estén en contacto con el agua, así evitaremos que se deposite la cal en los accesorios, después diluir en un paño un poco de jabón líquido con agua para limpiarlo perfectamente.

ATENCIÓN

No emplear nunca, detergente con sustancias abrasivas o con base ácida, amoníaco, acetona, lejía, ácidos varios, vinagre puro o esponjas abrasivas. El uso de los productos, pueden deteriorar irremediamente la superficie de los accesorios e Hidroglass no se hará responsable.

CONSEJOS PARA EL MANTENIMIENTO Y LIMPIEZA

La cal y la suciedad depositada en los accesorios se podrán lavar con una solución de agua y vinagre (concentración máxima de vinagre 15%, que sería 15 cl de vinagre en un litro de agua) después lavar con agua y jabón y aclarar.

For the care of Hidroglass products and keep them in perfect condition, it is advisable to dry with a cloth or cloth accessories (hinges and components), which are in contact with water, to avoid lime deposits on the accessories, then dilute in a cloth a little liquid soap with water to clean it perfectly.

ATTENTION

Never use detergents with abrasive or acid-based substances, ammonia, acetone, bleach, various acids, pure vinegar or abrasive sponges. The use of these products may cause irreparable damage to the surface of the accessories and Hidroglass will not be held responsible.

TIPS FOR MAINTENANCE AND CLEANING

Limescale and dirt deposited on the accessories can be washed with a solution of water and vinegar (maximum concentration of vinegar 15%, which would be 15 cl of vinegar in one liter of water) then wash with soap and water and rinse.

Para cuidar dos produtos Hidroglass e mantê-los em perfeitas condições, é aconselhável secar os acessórios (dobradiças e componentes) que estão em contacto com a água com um pano ou estopa, para evitar que o calcário se deposite nos acessórios, depois diluir um pouco de sabão líquido com água num pano para limpá-los perfeitamente.

ATENÇÃO

Nunca utilizar detergentes com substâncias abrasivas ou ácidas, amoníaco, acetona, lixívia, ácidos diversos, vinagre puro ou esponjas abrasivas. A utilização destes produtos pode provocar danos irreparáveis na superfície dos acessórios e a Hidroglass não pode ser responsabilizada.

CONSELHOS DE MANUTENÇÃO E LIMPEZA

O calcário e a sujidade dos acessórios podem ser lavados com uma solução de vinagre e água (concentração máxima de vinagre de 15%, ou seja, 15 cl de vinagre para um litro de água), depois lavar com água e sabão e enxaguar.

made in Spain



Hidroglass

Tel:95428877

fax:954529633

www.hidroglass.com

